

**Wolffpac
Technologies**



Williams™ System 6A-9 Replacement Display Kit



Assembly Instructions

wolffpactech.com

When assembled, this display will replace the displays used on many Williams solid state pinball machines which use the “System 6A”, “System 7” or “System 9” controller. For the complete list of compatible machines, see the list at the end of these instructions.

Tools:

Soldering iron - A small to medium power soldering iron of 25-50 watts with a small tip, preferably temperature controlled, is recommended.

Wire cutters - A set of diagonal or wire cutters intended for cutting electronic component leads.

Alcohol –Isopropyl Alcohol, Denatured Alcohol or Flux Remover to be used for cleaning the board after assembly.

Solder - Use only solder designated for electronic component assembly. Either lead-based or lead-free flux-core solder are both acceptable.

→ Use of solid core, acid core or plumbing solder is not acceptable and will void the warranty. ←

All soldering should be done on the bottom (non-printed) side of the boards. This kit uses “old school” through-hole components requiring only basic soldering skills to assemble. However, if you have never soldered before or are unsure of your skill level, it is recommended that you first practice soldering on a scrap board before beginning to assemble this kit. There are many references on the internet which can help you learn how.

 **Caution - Warning**









Solder melts at around 400°F to 600°F (200°C to 300°C). Remember to use care when soldering as both the soldering iron and solder are extremely hot and can produce serious burns. Make sure that you use an appropriate work surface since molten solder may drip and hot solder and components may damage or burn many materials.

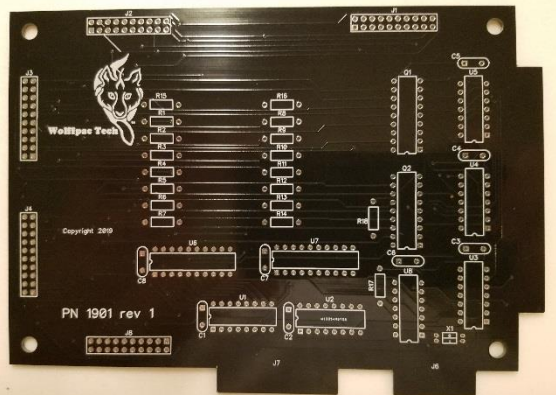

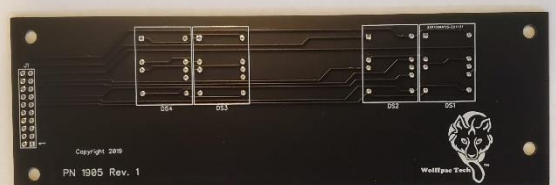

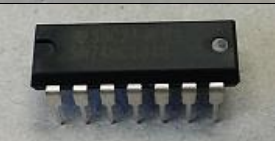

Eye protection is recommended as solder can splash and component leads may fly when cut.

We are not responsible for any damage or injury as a result of assembling this kit.

Remember: Solder and components will remain very hot for several minutes after soldering.

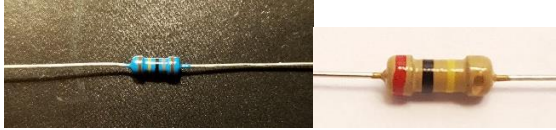
Parts List:

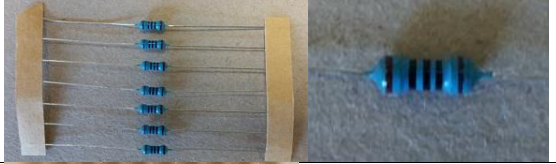
Part Description	Ref	Qty	
Printed Circuit Board 'Master', Marked: P/N 1901		1	
Printed Circuit Board 'Numeric', Marked: P/N 1904		4	
Printed Circuit Board 'Credit', Marked: P/N 1905		1	
IC, Marked: ULN2803 or TBD62083	Q1, Q2	2	
IC, Marked: CD4543	U1, U2	2	
IC, Marked: 74HCT04	U3, U4, U5	3	
IC, Marked: 74ACT541	U6, U7	2	
IC, Marked: 74HCT08 Or 74ACT08	U8	1	
Capacitor 0.1uF, Marked: 104	C1-C8	8	

7-segment LED Display	DS	32	
7-digit Foam Bezel		4	
2-digit Foam Bezel		2	
Resistor, 180K Ohm Marked Brown-Grey-Black-Orange-Brown Or 200K Marked Red-Black-Yellow-Gold	R17, R18	2	
Resistor, 0 Ohm Marked Black (Not required for PCB 1901 rev 4 or later)	X1	1	
Resistor, See table 1 for value and marking based on the color of the LED digits in your kit:	R1-R16	16	
Connector, 0.1", 2x10, straight	J1-J4, J8	5	
Connector, 0.1", 2x10, right angle	J1	5	

LED color	R1-R16 Value	Marking
Orange	120 Ohm	Brown-Red-Black-Black-Brown
Red	150 Ohm	Brown-Green-Black-Black-Brown
Blue	100 Ohm	Brown-Black-Black-Black-Brown
Green	150 Ohm	Brown-Green-Black-Black-Brown
White	100 Ohm	Brown-Black-Black-Black-Brown

Start Here:

Before starting, check the components received against the parts list on page two. (We do occasionally make mistakes!) If any components are missing, or you have any questions regarding these assembly instructions please contact Wolffpac Tech at 'wolffpactech@gmail.com'.

If you have any problems with the display after assembly, you may contact Wolffpac Tech at 'wolffpactech@gmail.com'. If you need to return the display for repair, we will provide a pre-paid return label. Any problem found to be due to defective components will be repaired free of charge within 1 year of purchase. Any problem found to be due to assembly error or damage will be charged for postage and the cost of any components which need to be replaced.

'Master' Board:

Step 1: Start with the larger 'Master' PC Board (marked P/N 1901):

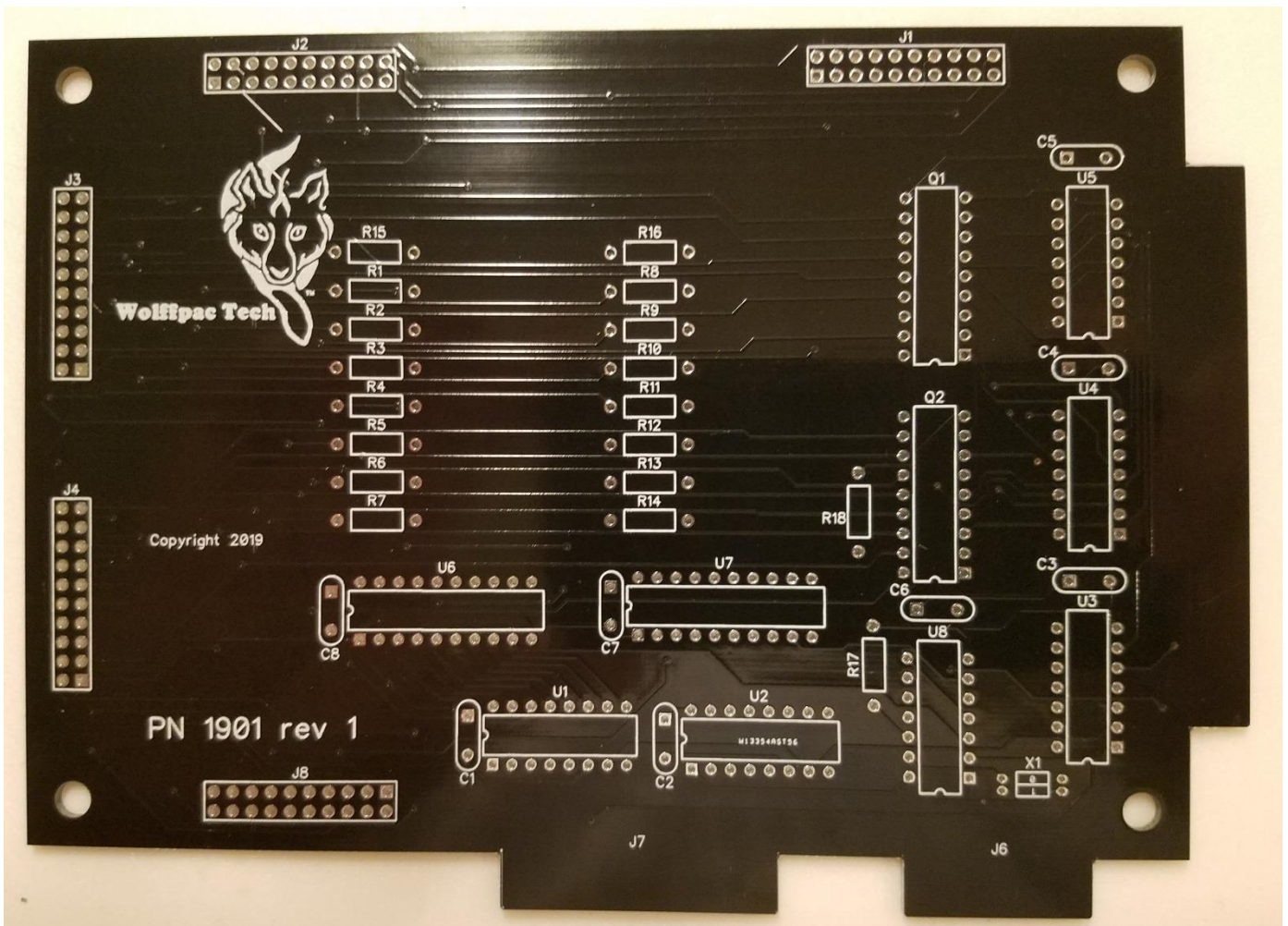

Insert U1 (CD4543) into the board from the top side (the side with the lettering) so that one pin goes through each hole at the location labeled 'U1'. Each chip is marked with a 'U'-shaped notch on one of the short ends:



This end should line up with the notch printed on the PC board. You may find that you need to bend the legs of the chip slightly in order to get both rows to line up with the holes in the board. You can do this with needle nose pliers or by laying the chip on its side with the pins of one side on a hard surface pointing away from you and gently pressing down and away on the body of the chip. Be careful not to bend the pins too far. Once inserted, bend the pins at the corners from the bottom slightly in order to hold the chip in place.

Make sure that all the pins from the chip are completely inserted through the holes in the board before soldering in place from the bottom. Repeat for U2.

Step 2. Repeat for U3, U4 and U5 (74HCT04)

Step 3. Repeat for U6, and U7 (74ACT541)

Step 4. Repeat for U8 (74HCT08 or 74ACT08)

Step 5. Repeat for Q1 and Q2 (ULN2803 or TBD62083).

Step 6: Locate resistor R1. Bend the leads of the resistor approximately 90° near the body of the resistor so that it forms a 'U' shape. Do not force the bend any closer than it will go with light finger pressure or you may damage the component. Insert the resistor into the board at the position marked R1 on the board. The direction does not matter. The leads should line up easily with the holes on the board. Once inserted through the board, bend the leads slightly from the bottom to hold the resistor against the board. Solder from the bottom. Trim the excess leads from the bottom of the board with diagonal cutters leaving about 1/16 inch. Repeat for R2-R16

Step 7: Locate and install resistors R17 and R18 (180K ohm).

Step 8: If you have a rev 4 or later display controller board, X1 is not used. Skip this step and proceed to the next step.

Locate X1. This is used to select if the 'comma' on the display is enabled. To enable the comma, install X1 in the location marked with a '1'. To disable the comma, install X1 in the location marked with a '0'. Note that the other location should remain unpopulated.

Note: System 6A machines do not support commas

Step 9: Locate capacitors C1 –C8. Insert one capacitor at the positions marked C1 on the board. The direction of these component does not matter. Bend the leads slightly from the bottom of the board to hold in position and solder in place. Trim the excess lead length to about 1/16 inch. Repeat for C2-C8.

Step 10: Locate connector J1. Make sure you are using the straight connector. Solder one pin from the back of the board. Confirm that the connector is fully seated against the board. If not, reheat the pin while pressing on the connector. Be careful not to get burned; the pin will get **very** hot on the top side of the board! Once the position of the connector is good, solder the remaining pins. Repeat for J2, J3, J4 and J8.

'Slave' Boards:

Step 1: Your kit will come with 4 'Numeric' display boards marked P/N 1904:

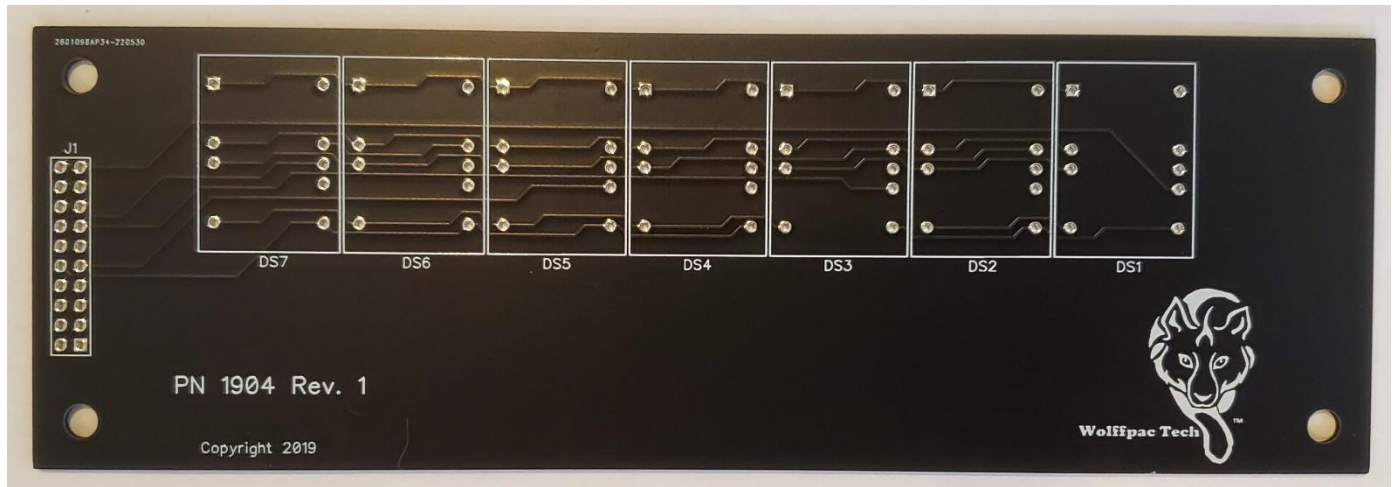

Step 2: Install one 2x10 right angle connector at the location marked J1. It is recommended to first solder only one pin on the connector. Verify that the connector is flush with the circuit board and the pins are parallel to the board:



If not, reheat the one pin and adjust the connector. Solder the remaining pins.

Step 3: 7-segment LED's.

The LED's are installed in positions DS1-DS7.

Install one 7-segment LED in each position. Ensure that the component is installed with the comma (',') towards the bottom of the board and that all pins are correctly seated in the holes. Lay the board face down and solder one pin in each row. Inspect to ensure that the LED is seated flush with the PC board. If not, reheat the pin while pressing on the display from the front of the board. Once the LED is correctly seated, solder the remaining pins. Repeat for the remaining 6 LED displays.

Step 4: Your kit will come with 1 'Credit' display board marked P/N 1905:

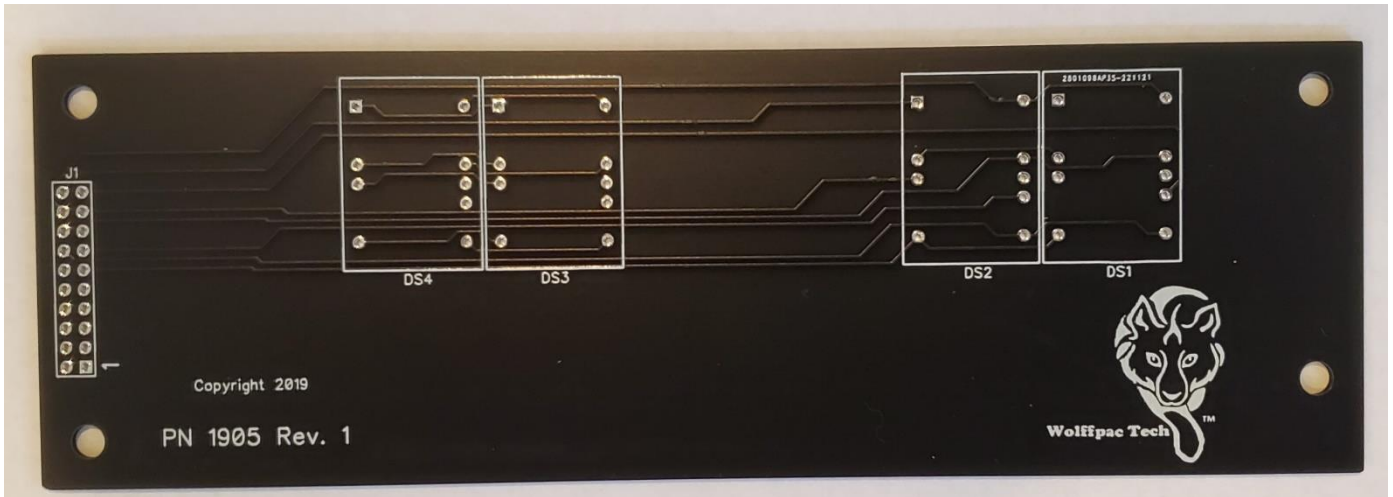

Step 5: Install one 2x10 right angle connector at the location marked J1. It is recommended to first solder only one pin on the connector. Verify that the connector is flush with the circuit board and the pins are parallel to the board. If not, reheat the one pin and adjust the connector. Solder the remaining pins.

Step 6: 7-segment LED's. The LED's are installed in positions DS1-DS4.

Install one 7-segment LED in each position. Ensure that the component is installed with the comma (',') towards the bottom of the board and that all pins are correctly seated in the holes. Lay the board face down and solder one pin in each row. Inspect to ensure that the LED is seated flush with the PC board. If not, reheat the pin while pressing on the display from the front of the board. Once the LED is correctly seated, solder the remaining pins. Repeat for the remaining 3 LED displays.

Final Assembly

Step 1. Wipe or rinse the boards with Isopropyl Alcohol, Denatured Alcohol, Flux Remover or water depending on the type of solder used to remove the solder flux residue.

Step 2. When the boards are completely dry, peel the clear plastic protective film from the front surface of each LED display.

Step 3. Remove the paper backing covering the adhesive from the 2-digit foam bezel. Carefully line the openings with the LEDs on the 1905 board and install as shown below.

Note: The adhesive is very aggressive. Be careful when handling the bezel after removing the paper backing to avoid sticking it to something or somewhere you didn't intend!

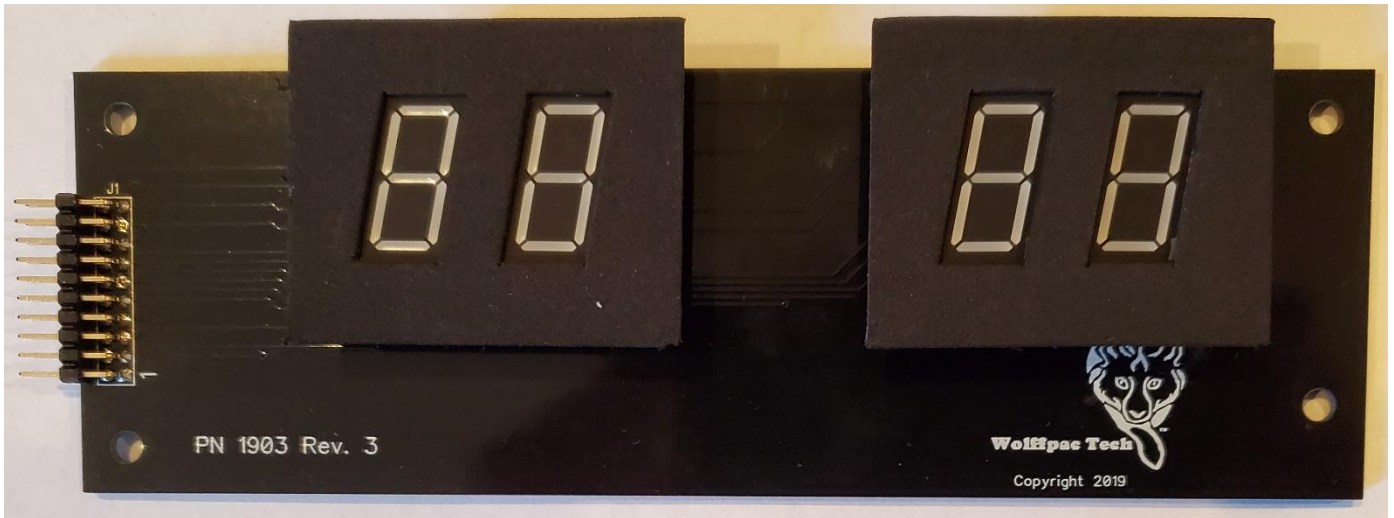

Step 4. Remove the paper backing covering the adhesive from one of the 7-digit foam bezels. Carefully line the openings with the LEDs on one of the 1904 boards and install as shown below. Repeat for the remaining three 1904 boards



Step 5. With the power off, install the displays in your pinball machine and attach the original cables. The high voltage power supply in your pinball machine is no longer required. If you want, you can remove the fuse on the power supply board to disable it.

Note: It is okay to operate the system without any or all of the slave displays installed.

Caution: All five boards must be changed to use this display. Do not mix components of the original display with this display. Operating your pinball machine with any of the slave displays attached to the original master board will damage them and void the warranty.

Apply power and enjoy!

This is believed to be an accurate list of machines with displays compatible with this replacement. Since we are unable to test this board in every configuration, we take no responsibility for any errors. However, we do welcome feedback as to any errors that are found so that we can update this list.

System 6A

Algar

Alien Poker

System 7

Barracora

Black Knight

Black Knight Limited Edition

Cosmic Gunfight

Defender

Firepower II

Joust

Jungle Lord

Laser Cue

Pharaoh

Solar Flare

Star Light

Time Fantasys

Varkon

Warlok

System 9

Sorcerer

Space Shuttle

2

1

B

B

A

A

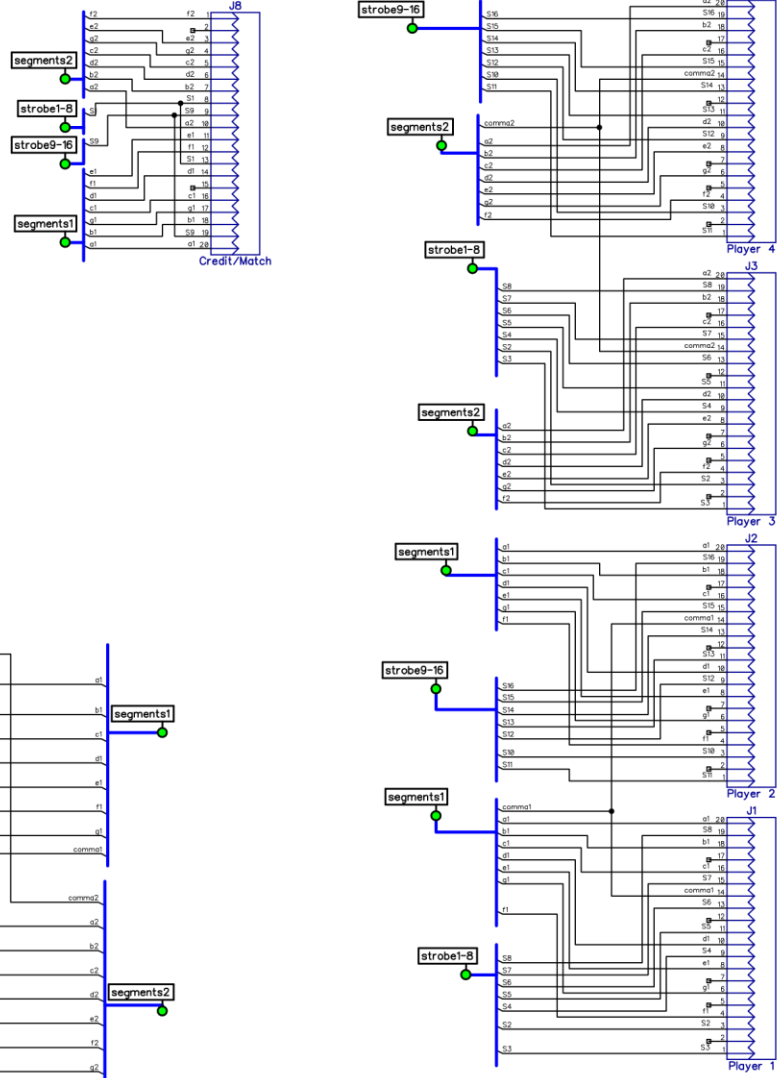
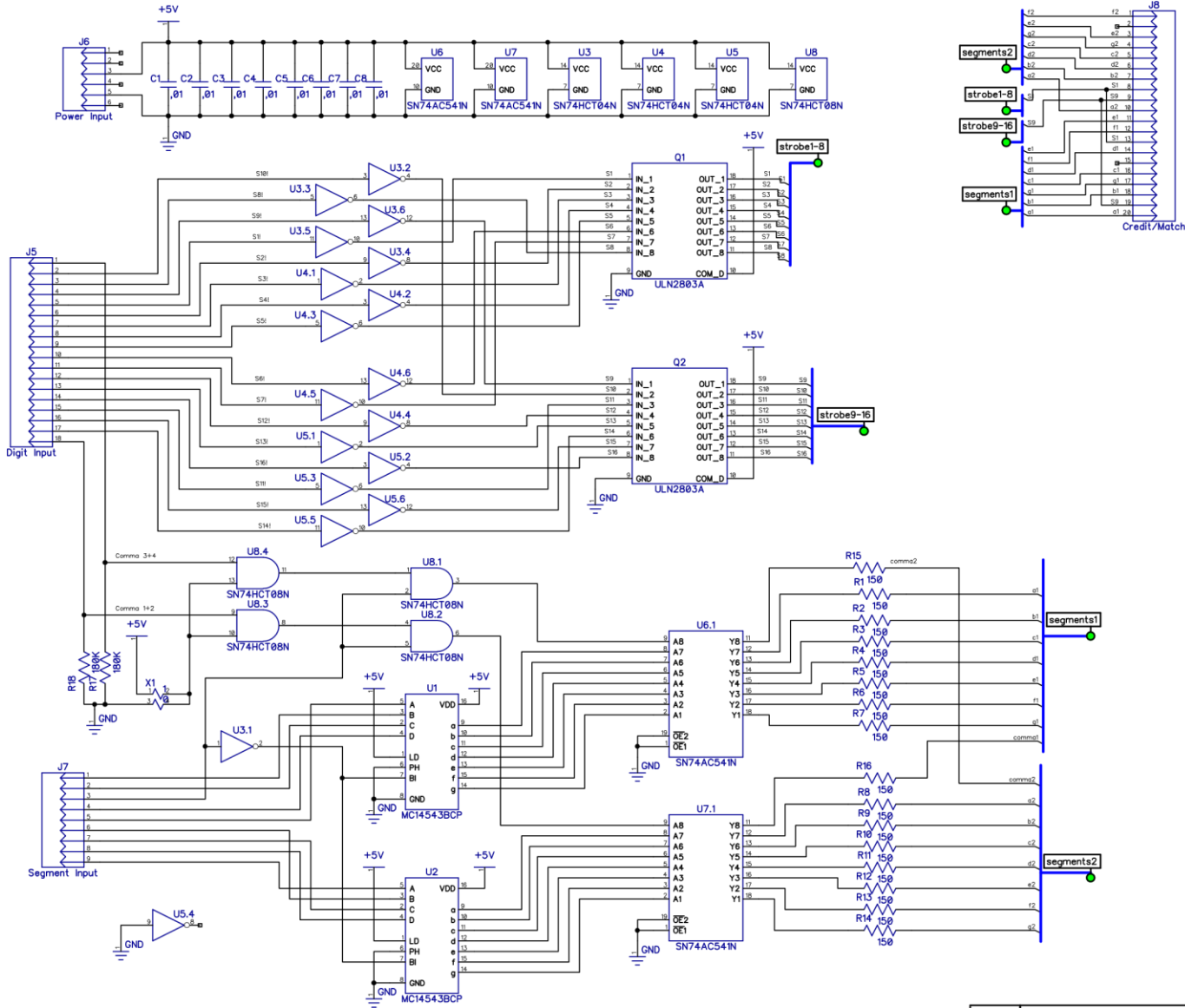

2

1

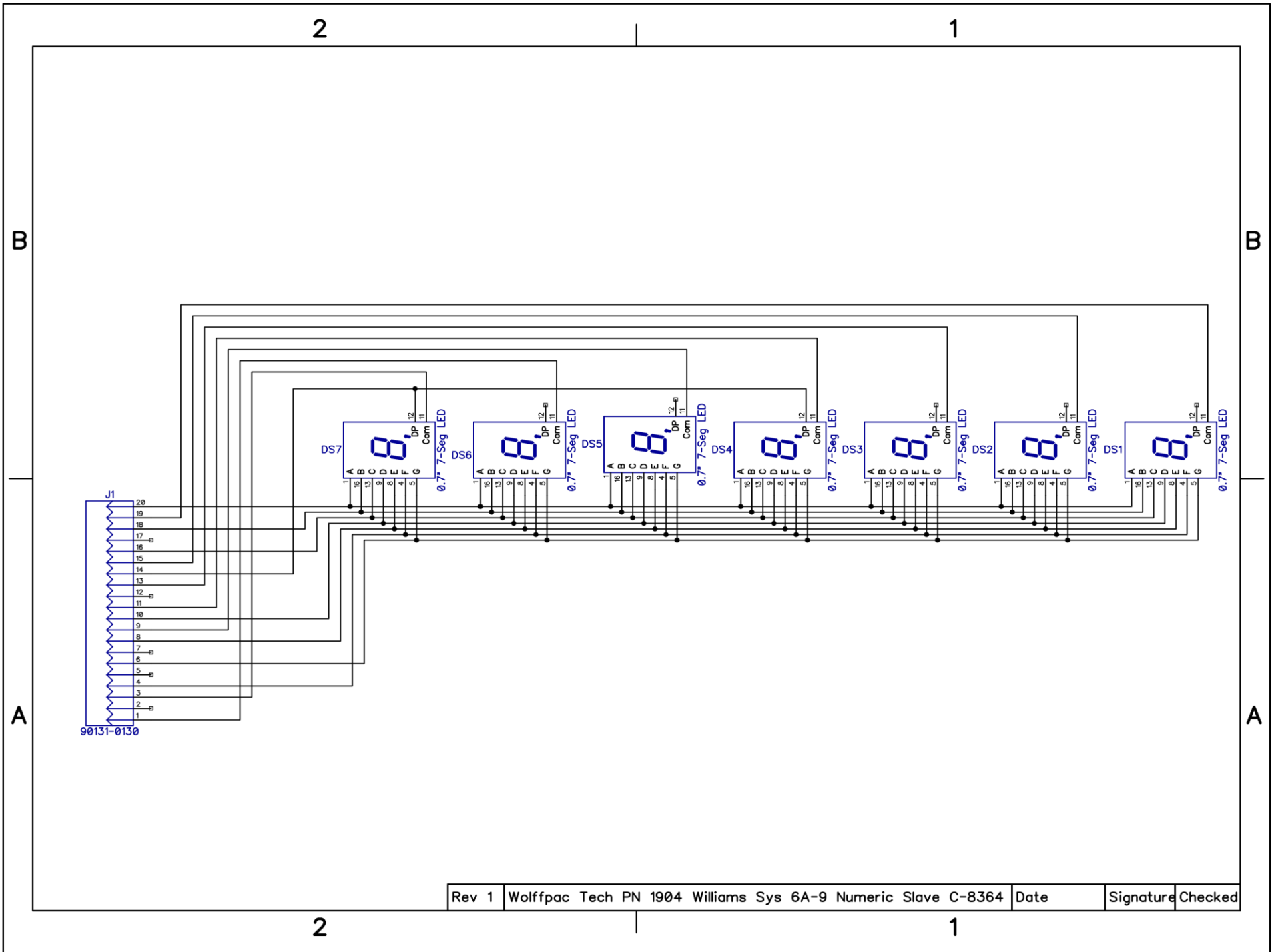

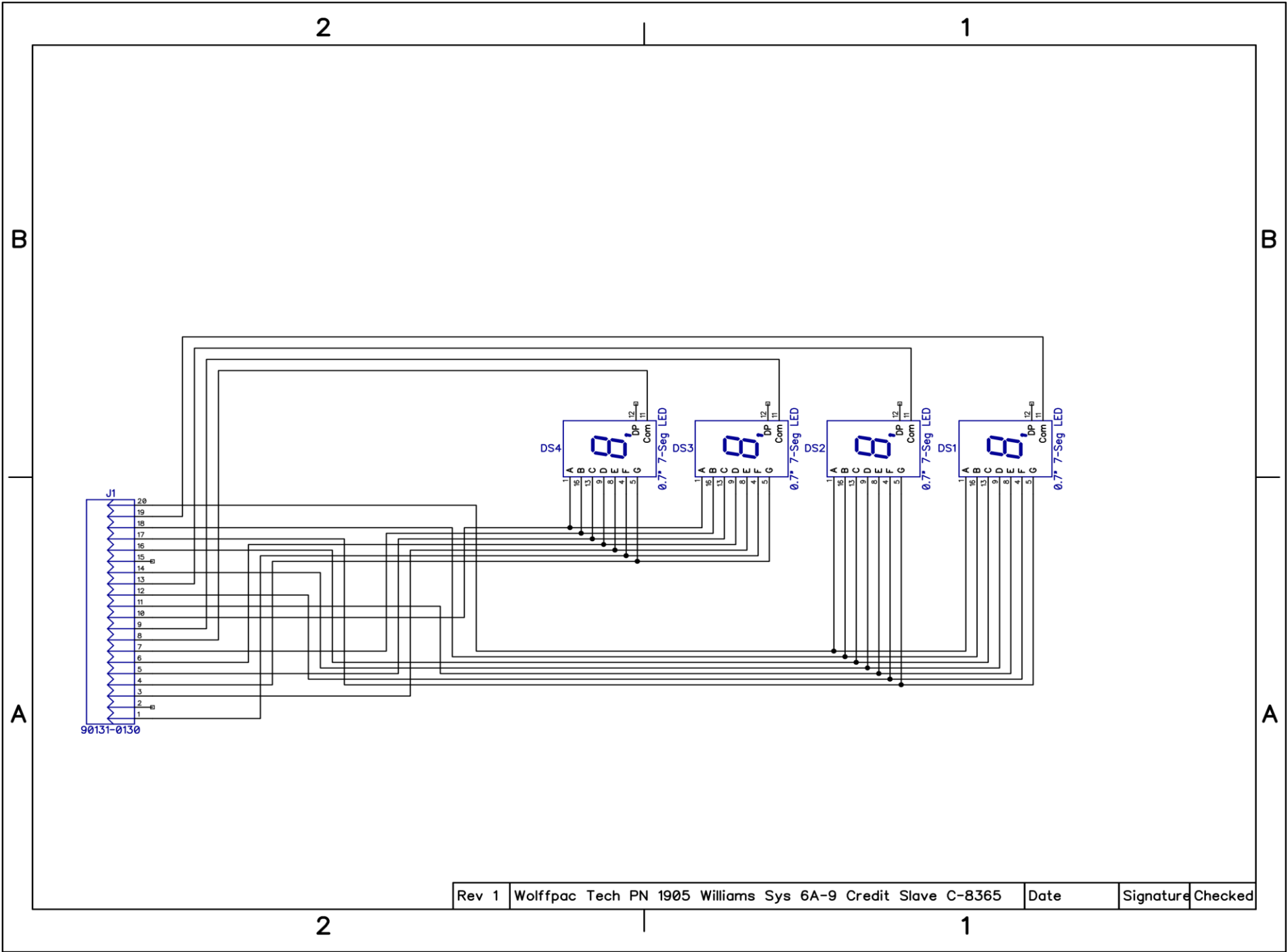

Rev 1	Wolffpac Tech PN 1905 Williams Sys 6A-9 Credit Slave C-8365	Date	Signature	Checked
-------	---	------	-----------	---------